

TECHNICAL BULLETIN

Raptor Electrocutions and Distribution Pole Types

by: **Rick Harness**

EDM International, Inc.
Fort Collins, Colorado

Abstract

The electrocution of raptors and larger perching birds is a global hazard of overhead distribution construction, especially in treeless areas with abundant prey where poles make attractive perches. Disturbed by the continuing large numbers of raptors, particularly eagles, electrocuted along power lines, the U.S. Fish and Wildlife Service has begun to step up enforcement of the Migratory Bird Treaty Act and the Bald and Golden Eagle Protection Act. In 1999, Moon Lake Electrical Association, Inc. (MLEA) of Utah was charged with electrocuting 17 large raptors and violating the Migratory Bird Treaty Act and the Bald and Golden Eagle Protection Act. MLEA was ultimately given three years of probation, ordered to pay \$100,000 in fines and restitution, and required to retrofit structures dangerous to migratory birds.

Electrocution hazards can be greatly reduced through modifications to existing design standards. However, most modifications in North America are designed for use on wood poles and crossarms. As other materials (e.g. fiberglass, concrete and steel poles) are used as an alternative to wood, construction techniques should adhere to established engineering criteria such as Basic Impulse Insulation Level (BIL) and state-of-the-art raptor protection.

Because steel and reinforced concrete poles are more conductive than wood or fiberglass,



Raptor Electrocutions – Background

As early as 1971, the electrical utility industry became aware of the raptor electrocution issue. Due, in large part, to investigations of poisoning and shooting deaths of bald and golden eagles in Wyoming and Colorado, it was discovered that many birds were also dying by power line electrocutions. By 1972, the U.S. Rural Electrification Administration (REA) published a first set of industry guidelines for minimizing raptor electrocution problems along power lines. In the ensuing years a steady stream of studies and publications, many generated by sources from within the industry, fed a rapidly accumulating knowledge base pertaining to the issue (Olendorff, et. al., 1981). Currently, the most complete and up-to-date document dealing with the raptor protection issue is *Suggested Practices for Raptor Protection on Power Lines: The State of the Art in 1996*, published by the Avian Power Line Interaction Committee, the Edison Electric Institute, and the Raptor Research Foundation.

After 1972 many investor owned utilities (IOU's) and REA cooperatives adjusted line configurations and grounding practices, reducing raptor electrocutions. Today Rural Utilities Service (RUS) cooperatives (formerly REA) are required to construct lines with nonconducting wood braces, and to install pole grounds so they are raptor safe. These changes are reflected in the U.S. Department of Agriculture engineering publication entitled, "Specifications and Drawings for 7.2/12.5Kv. Line Construction" (RUS Form 804). Additional raptor mitigating measures are up to individual RUS members, with many choosing to reduce eagle electrocutions by providing increased conductor separation. The increased separation is often accomplished by substituting 10-foot wood crossarms for conventional 8-foot arms, providing 60-inches of separation between primary conductors. The Raptor Research Foundation recommends a minimum of 60-inch spacing between phases and phase-to-ground to minimize eagle electrocutions (APLIC 1996). A large female golden eagle can have a 90-inch wingspan, 54 inches between wrists. The 60-inch spacing was selected to minimize electrocutions of immature eagles when they begin or terminate a flight.

Although utility construction practices have improved since 1971, some raptor electrocutions still persist. These electrocutions often cause outages resulting in damaged equipment, safety problems and loss of service to consumers. A 1993 Institute of Electrical and Electronics Engineers, Inc. (IEEE) survey stated the majority of their respondents still experience outages caused by squirrels, birds, raccoons and snakes (IEEE Power Engineering Society 1993). Nationwide, animals are the third leading identifiable cause of all power outages, and birds cause more outages than any other animal (Southern Engineering Company 1996). The United States Department of the Interior investigated 4,300 eagle deaths from the early 1960's to 1995 and reported electrocution as the second greatest cause of all detected golden eagle mortality and the fourth greatest cause of bald eagle deaths (LaRoe et al. 1995) (Photo 1).

Electrocutions are not restricted to the United States but occur worldwide. Cape vulture electrocutions have been a persistent problem in South Africa (Markus 1972, Jarvis 1974, Ledger and Annegarn 1981). Haas (1980) reported 14 diurnal and 5 nocturnal species of raptor electrocuted by power lines in West Germany; Herren (1969) recorded owl electrocutions in Switzerland. Bevanger (1994) surveyed 175 Norwegian power companies and most respondents stated they believed their facilities electrocuted raptors.



Photo 1. A juvenile golden eagle electrocuted by a distribution power line.

Raptor Electrocutions

The 2nd International Conference on Raptors (October, 1996) organized by the Raptor Research Foundation, included an Energy Development Symposium. Representatives attending the conference from the United States, South Africa, Tasmania, Russia, Italy and Spain all presented papers on persistent avian electrocutions.

Electrocutions are also a restrictive factor for some raptor populations (APLIC 1996). At one point there were only 60 California condors left in the North America. Today condors are subjected to mock power poles and low electrical shocks to deter perching before they are released (Graham 2000). The electrocution of Egyptian vultures may be responsible for the overall decline of the species near Khartoum, Sudan (Nikolaus 1984). Electrocutation is also the primary known cause of death for the endangered Spanish eagle in and around Doñana National Park, Spain (Ferrer and Fernando 1991, Ferrer et al. 1991). They estimate up to the 187 miles of power lines in and around the park might kill 1200 raptors per year. Ferrer and Fernando (1991) also conclude techniques for reducing electrocutions in and around Doñana National Park, Spain are more effective than other management techniques employed to increase eagle productivity.

The electrocution problem will presumably intensify as power lines are constructed in developing countries with expanding human populations such as Africa, South America, and Asia (Bevanger 1994). Mitigating measures should be encouraged globally because they will not only minimize electrocutions, but will also minimize power outages (Negro and Ferrer 1995). Reducing outages may save utilities money in the long term and will certainly improve system reliability. For example, May 9, 2000 the southern half of Portugal, including the capital Lisbon, had a massive power outage. The outage lasted almost 2 hours and affected several million people. A bird caused a short circuit on a power line and the automatic protection system at a major substation did not function.

Raptor Electrocutions – Legal Issues

Despite a wealth of available information, some electrical utilities continue to lag behind standards of raptor protection along their power lines. In so doing, these utilities expose themselves to the possibility of prosecution under statutes that protect the birds that perch on those lines. Disturbed by the continuing large numbers of raptors, particularly eagles, electrocuted along power lines, the U.S. Fish and Wildlife Service (USFWS) has begun to step up enforcement of the Migratory Bird Treaty Act (MBTA), the Bald and Golden Eagle Protection Act (BGEPA), and the Endangered Species Act (ESA). The first utility cited for violation of the Migratory Bird Treaty Act was Pacific Gas and Power of California. In 1993, the utility was fined \$1500 for violations and agreed to retrofit lines to safer standards. In 1998, Sand Point Electric of Alaska was fined \$500 and was likewise compelled to retrofit dangerous structures (Suazo 1998).

Most recently, however, a plea agreement between the United States Department of Justice and the USFWS with Moon Lake Electrical Association, Inc. (MLEA) of Utah ushered in an entirely new era of enforcement (Williams 2000). Under the agreement, MLEA was given three years of probation, ordered to pay \$100,000 in fines and restitution, and required to retrofit structures dangerous to migratory birds. MLEA was also required to enter into a Memorandum of Understanding (MOU) with the USFWS and to hire a qualified consultant to develop an Avian Protection Plan.

Altogether, MLEA was charged with six counts of violating the Migratory Bird Treaty Act and the Bald and Golden Eagle Protection Act. Although MLEA was charged with killing 17 large raptors (including, but not limited to, golden eagles), at least another 21 raptors in excess of the 17 enumerated in the charges had been electrocuted over a period of several years under the Association's power lines. Complicating matters for the utility was the fact that MLEA had been repeatedly notified of dangerous structures along their lines, but opted to retrofit only structures already known to have killed birds (Melcher and Suazo 1999). Multiple kills were also recorded under some structures.

In a pre-trial motion, MLEA argued that it had not deliberately killed any of the raptors and was therefore not liable to charges under either the MBTA or the BGEPA. Moon Lake argued, in part, that the MBTA and BGEPA were intended to apply only “intentionally harmful” activities such as those entailed in hunting, poaching, and trapping. District Court Judge Lewis Babcock denied this motion. In the case of the MBTA, Judge Babcock found that the language of the MBTA, “it shall be unlawful at any time, by any means, or in any manner, to pursue, hunt, take, capture, kill, attempt to take, capture, or kill ... any migratory bird ...,” does not restrict application to deliberate types of killing normally associated with poaching or hunting. While Judge Babcock allowed that innocent technical violations might be taken care of by a small fine, a case such as that of MLEA raises more serious issues. Specifically noted by the judge was the fact that MLEA failed to install inexpensive retrofits on 2,450 of 3,096 poles in the area in question. Additionally, Judge Babcock also rejected MLEA’s claim that they were subject to selective enforcement of the law, noting that “conscious exercise of some selectivity in enforcement is not in itself a federal constitutional violation so long as the selection was not deliberately based upon an unjustifiable standard such as race, religion, or other arbitrary classification (45 F.Supp.2d 1070).”

Violations of the MBTA are examples of strict liability crimes, meaning that a party can be convicted under the statute without demonstration of specific intent or guilty knowledge. In contrast to the MBTA, the BGEPA proscribes behavior by which an entity “knowingly or with wanton disregard for the consequences of his act” takes a Bald or golden eagle. Citing numerous precedents, Judge Babcock ruled that “take” includes any act of killing without respect to method.

Further, the judge found that a determination of whether or not MLEA had acted “knowingly or with wanton disregard” in the killing of the eagles was a matter for the jury’s determination and therefore not subject to challenge by a pre-trial motion (45 F. Supp. 2d 1070).

All said, if MLEA had not entered into a plea agreement, the Association would have stood trial on all six counts of the violations of both the MBTA and the BGEPA. This is the first significant case law of a utility being criminally prosecuted under the MBTA and BGEPA.

Although not applicable to the MLEA case, the Endangered Species Act may also apply in certain cases of avian electrocutions. Once again, the definition of “take” comes into play. Although a party must knowingly take a threatened or endangered species to be criminally liable under the ESA, civil penalties may apply in cases of strict liability as well.

All three of the Acts in question have provisions for substantial financial penalties (see Table 1). Under the MBTA, misdemeanor convictions can bring fines of up to \$15,000 per individual and \$30,000 per organization. Also, the law allows for up to six months of imprisonment for individuals involved in the illegal activity. Under the BGEPA, misdemeanor fines run much higher, up to \$100,000 per individual and \$200,000 per organization. A second conviction under the act allows for the fines to reach \$250,000 and \$500,000, respectively. In addition, prison terms of up to one year may be imposed. Finally, violations of the ESA carry similarly severe penalties. Convictions under the ESA carry fines of up to \$100,000 per individual and \$200,000 per organization, with the added possibility of a one-year prison term.

Table 1. Penalty Provisions in USFWS Statutes

Act	Penalty Provisions	Felony Class	Felony Jail	Felony Fines	Misdem. Class	Misdem. Jail	Misdem. Fines
MBTA	16 USC 707	E	2 Yrs.	500,000/ 250,000/	B	6 Mo	15,000/ 30,000
BGEPA	16 USC 668	E		500,000	A	1 Yr	100,000/ 200,000
ESA	16 USC 1540				A	1 Yr	100,000/ 200,000

Raptor Electrocutions

It is important to note the MBTA protects all migratory birds, not just raptors. There are over 800 species of migratory birds in North America and the only ones not given protection are non-native species including the house sparrow, European starling, feral pigeon, and monk parakeet.

USFWS Director Jamie Rappaport Clark addressed the Edison Electric Institute - Natural Resources Workshop on April 26, 1999. This speech was a month after the MLEA settlement. In that speech the Director stated the USFWS would rather partnership with utilities to solve raptor problems than to step up enforcement of laws protecting migratory birds. Director Clark also stated their goal is voluntary compliance on the part of the industry and the USFWS will work with any and all utilities to make this happen.

Numerous factors in addition to raptor size (Table 2) and conductor separation contribute to electrocutions. Inclement weather, particularly wet snows are a major contributing factor to many eagle electrocutions (Benson 1981). Feathers are good insulators unless they become wet. Raptors with wet feathers are ten times as vulnerable to electrocution above 5,000 volts (Nelson 1979a; Olendorff et al. 1981). Dry birds contacting live wires with their beak and foot however can still be killed at voltages below 5,000 (Olendorff et al. 1981). Wet birds may also have greater difficulty navigating around energized conductors when flying to and from poles.

Table 2. Average Size and Weight of Six Raptor Species.

Species	Length (In.)	Wingspan (In.)	Weight (Lbs.)
Golden Eagle	30	79	10
Bald Eagle	31	80	9.5
Ferruginous Hawk	23	56	3.5
Red-tailed Hawk	19	49	2.4
Rough-legged Hawk	21	53	2.2
Swainson's Hawk	19	51	1.9

The Mechanics of an Electrocution

Animals are not hurt or injured by voltage alone. Squirrels running on or birds perching on an energized wire without incident are an everyday reminder of this fact. Injury occurs when an animal becomes a path for current flow. As current flows from a higher potential (or voltage) to a lower potential (often ground), the animal must complete a connection between the two potentials to have current flow through it. In the case of a distribution power line, high potentials exist on the three phase conductors, and low potential exists on any conducting part of the structure connected to an earth ground. The other case of potential differences occurs between phase conductors, where one phase of voltage can "appear" as a lower potential to another phase of voltage. In summary, anywhere an animal can create a path between high voltage and ground (or another phase of high voltage), electrocution can occur (Photo 2).

Wind direction relative to utility crossarm orientation also affects the probability of electrocution (Boeker 1972; Nelson and Nelson 1976; Nelson 1977; Benson 1981). Crossarms mounted perpendicular to the wind allow raptors to easily soar away from the structure and attached wires. Raptors taking off from crossarm-mounted parallel to prevailing winds can more easily be blown into energized conductors. Wind orientation presumably places inexperienced fledgling birds at greatest risk.

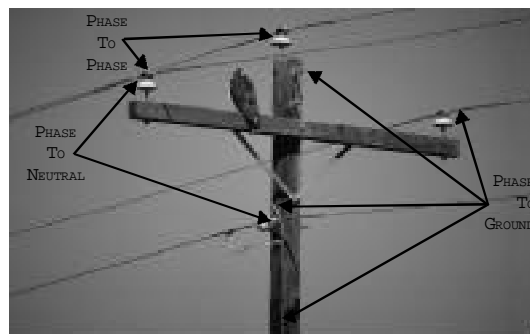

Photo 2. Electrocutions can occur if an animal spans phase-to-phase, phase-to-neutral, or phase-to-ground.

Raptor electrocutions often fluctuate seasonally. In the winter, power line poles are valuable sit-and-wait hunting sites, allowing raptors to seek prey without expending energy on active flight hunting (Benson 1981). During the spring, raptors may increase their exposure to electrocution by utilizing pole structures as nesting sites. Seasonal fluctuations of prey abundance may also influence the number of raptors electrocuted in a particular area (Olendorff 1972; Benson 1981).

Age is a significant factor in golden eagle electrocutions. Parents feed the immature eagles the first few months after fledging. During this period the young eagles gain flight experience by short perch-to-perch flights. As these birds begin to hunt for themselves they generally still rely on stationary perches. The young eagles are inexperienced in takeoffs and landings and less adept at maneuvering than adults (Nelson and Nelson 1976; Nelson 1979a, 1979b). Short flights from perch-to-perch, hunting from the perch and takeoff and landing inexperience all place young eagles at a high risk for electrocution (Olendorff 1993). Dawson and Mannan (1995) indicated that fledgling Harris' hawks in and near Tucson, Arizona are also especially susceptible to electrocution during the first 2 weeks after fledging.

Wood, Fiberglass, Concrete, and Steel Poles

From the beginning, North American distribution utilities selected wood as the material of choice for poles and crossarms. Accordingly, most raptor-proofing techniques are designed for use on wood pole structures. Recently other materials such as fiberglass, concrete and steel poles are being used in distribution line construction. As these materials are used as an alternative to wood, construction techniques must adhere to established engineering criteria such as Basic Impulse Insulation Level (BIL) and state-of-the-art raptor protection.

BIL and Line Construction

The ability of a distribution line to withstand, isolate, and quench the effects of lightning strikes must be considered when designing an overhead distribution system.

This factor is particularly important for rural distribution systems, where buildings, structures, trees, etc. are typically fewer in number near the line, and thus provide less protection from direct lightning strikes to the line.

When lightning strikes a distribution line, a current and voltage surge is placed on the line. It travels down the line looking for a path to ground, which is the path of least resistance, or lowest insulation level. At this point, the surge may cause a flashover between phases or a phase and ground, which is to be avoided. The air space between conductors yields large amounts of resistance to flashover, so the path of least resistance is normally found somewhere on a structure. Proper structure design keeps the insulation between phases high enough to avoid most flashovers, and channels the energy to ground through the use of shield wires or lightning arresters.

The ability to withstand flashovers caused by lightning surges is the Basic Impulse Insulation Level or Critical Impulse Flashover rating. After field-testing and debate, 300 kV BIL has become the accepted standard for 7.2 kV and 14.4 kV (line-to-ground) on RUS distribution systems. RUS has stated this as a design standard for wood pole construction, and is releasing a draft standard stating the same for distribution construction using steel poles (RUS 2000).

BIL and Steel/Concrete Pole Construction

The current structure design standards for using wood and fiberglass poles need no modifications to provide a minimum of 300kV BIL. However, this does not apply for standards using steel and concrete poles. Since wood has insular value, part of the BIL in the structure design comes from the BIL of the wood poles and crossarms. However, steel poles and crossarms have no insular value, thus providing no measure of BIL to the structure. Spun concrete poles also have an internal metal rebar support structure and are considered to have no insular value. Appropriate BIL can be achieved in steel and concrete pole structure design through the use of either fiberglass or wood crossarms (instead of steel crossarms), longer insulators, and fiberglass pole-top pin extensions.

Raptor Electrocutions

Raptors and Steel/Concrete Pole Construction

Non-wood poles are commonly used in distribution line construction in Europe and other parts of the world and Janss and Ferrer (1999) report differences in electrocution rates of birds on wooden versus metal power poles. Whereas typical electrocution problems in North America are often wire-to-wire, European problems are often wire-to-pole. Accordingly, European mitigation methods differ because measures effective on wooden power poles have not solved electrocution problems on metal poles (Negro and Ferrer 1995). For example, artificial perches attached at “safe” locations (far from conductors) on poles, and perch guards designed to prevent raptors from contacting conductors, are less effective in preventing electrocutions than modifications that insulate conductors from birds. The use of pin-type insulators on steel is even illegal in parts of Spain due to lethality to raptors (Janss and Ferrer 1999). A European raptor-safe steel pole-top assembly that may be of use in North America was presented at EPRI’s “Avian Interactions With Utility Structures” workshop held in Charleston, South Carolina on December 2-3, 1999. RUS is in the process of evaluating the unit for use on their systems.



Photo by Cynthia Melcher
Photo 3. Concrete pole associated with raptor electrocutions in San Pedro, Mexico.

Concrete poles with their internal support structure of metal rebar, pose similar risks to electrocution as steel poles. A 102 mile long concrete pole line constructed with steel crossarms near Janos, Mexico was recently inspected and 49 dead birds were discovered, suspected to be electrocutions (pers. comm. Gail Garber 2000) (Photo 3). Of these 10 were ferruginous hawks, 9 were golden eagles including 5 adults; the rest were a combination of red-tailed hawks, prairie falcons, and one American kestrel.

Sometimes non-wood poles are used because they are not susceptible to woodpecker damage. In some regions of the United States, woodpecker damage to wood poles is the most significant cause of pole deterioration (Abbey et al. 1997). However, steel or concrete distribution power lines constructed utilizing standard utility configurations, can significantly reduce phase-to-ground clearances needed by birds of prey. These reduced clearances can result in electrocuted birds of prey (Photo 4). Because fiberglass poles are insulated, they can be framed in a similar fashion to wood poles.



Photo 4. Electrocuted red-tailed hawk under a steel distribution underbuild mounted on a steel transmission pole.

Raptor Electrocutation Mitigation Measures

The following discussion covers typical methods used to frame different pole types (e.g. wood, fiberglass, concrete, steel) to raptor-safe standards. This section addresses the application of mitigation measures to new construction only. Retrofitting mitigation measures are similar to new construction but generally entail higher labor costs. The increased labor is due to working around energized conductors. Poles requiring retrofitting are also often located in remote locations, requiring greater travel time. Some utilities may also not allow hot gloving. This requires a utility to take an outage to retrofit structures, impacting both the utility and their consumers. Because of more labor associated with retrofitting, mitigating measures using more expensive materials that can be installed hot are often more attractive in retrofitting than in new construction.

RUS standards were selected because RUS requires specific BIL levels and their construction is standardized across the Nation. Investor Owned Utilities and Municipal Utilities also serve into rural areas and experience problems with raptor electrocutions but their construction standards are variable from utility to utility. For simplification, only the 12.5/7.2 kV design standards are used.

The figures on the following pages depict some typical RUS structure designs. The first structure shown in each figure depicts an unaltered design, with potential electrocution hazards highlighted. Subsequent structures in each figure depict various mitigation options reducing electrocution hazards. Wood, steel, concrete and fiberglass pole structures are designed to achieve 300 kV BIL required by the RUS.

A list of figures is as follows:

- Figure 1 – Single phase tangent, wood/fiberglass pole construction
- Figure 2 – Single phase tangent, steel/concrete pole construction
- Figure 3 – Three phase tangent, wood/fiberglass pole construction
- Figure 4 – Three phase tangent, steel/concrete pole construction

Each section discusses the cost differential between mitigating methods on a per structure basis. Tables contain a list of additional materials needed for these mitigation options (beyond the normal materials for the construction unit), plus estimated material costs based on manufacturers' suggested retail pricing. Labor costs were also included but may vary greatly between utilities, contractors, and methods of installation.

Differences between pole costs can also be disparate. In general, fiberglass and concrete distribution poles are much more costly than wood poles. Cost comparisons in this paper are limited to steel and wood because they are much closer in cost.

The price of wood and thin walled steel poles vary significantly depending upon a variety of factors including wood species, geographic location, framing requirements, coatings and class size. For purposes of this analysis for distribution line construction we have looked at data for an average of 40-foot class 4 southern pine pole prices compared to 40-foot class 4 thin-walled steel. Southern yellow pine was selected because it comprises approximately 80% of the wood pole market. Using this analysis we assume the average wood pole, including freight will cost \$210 and the average steel pole, including freight will cost \$280 or a difference of \$70.

It is important for the user to remember comparisons are on a per structure basis and the price analysis considers the thin walled steel poles sizes and thus cost comparisons, as being based upon wood equivalents. This is true only in Grade B design, when distribution is more likely to be designed to Grade C standards where significantly more or larger steel poles would be required to meet code in a manner equivalent to wood.

For raptor protection purposes, wood and fiberglass poles are treated as nonconductive although under certain weather conditions poles can become grounded due large amounts of moisture. Although electrocutions can occur on phase to wet wood, they are relatively rare (Harness 1997). Steel and concrete are treated as conductive for BIL and raptor protection.

Raptor Electrocutions

Fiberglass crossarms are sometimes employed on steel and concrete poles but cost more than conventional wood crossarms. For purposes of cost comparison, all structures were evaluated using wooden arms framed with wooden braces.

Different grounding methods are also used for steel poles. On all poles requiring ground rods (i.e. transformer, reclosers, etc.) the labor and material is the same at the pole base, but wood poles also require running a ground down the pole. For purposes of cost comparison, all wood structures were evaluated including the additional labor and material required to run a ground wire to the pole base.

Single Phase Tangent Structures

The most common distribution unit types located in rural areas are tangent structures. Figure 1 illustrates a typical single-phase tangent structure constructed on a wood or fiberglass pole.

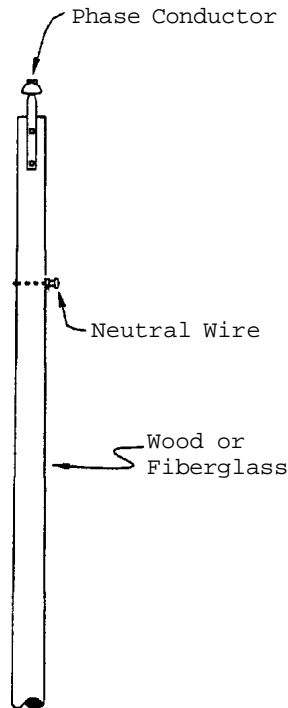

Figure 1. Typical rural distribution single-phase pole configuration, 7.2kV.

Single-phase lines are usually constructed without crossarms and support a single energized phase conductor on a pole-top insulator. Distribution tangent structures, without pole-top grounds or pole-mounted equipment, generally provide adequate separation for all raptors.

If steel or concrete is substituted for wood or fiberglass (Figure 2), the critical clearance for birds of prey is the phase-to-pole top (i.e. ground) clearance. A golden eagle's tail can extend 10 inches below its perch. Although dry feathers can withstand voltages up to 70 kV, wet feathers burn at 5 kV (Nelson 1979b). Therefore, a large bird of prey can be electrocuted while perching on a center phase pin under wet conditions if its tail feathers contact a grounded surface, such as a steel or concrete pole. The proximity of the wire to the steel pole also does not meet RUS BIL requirements.

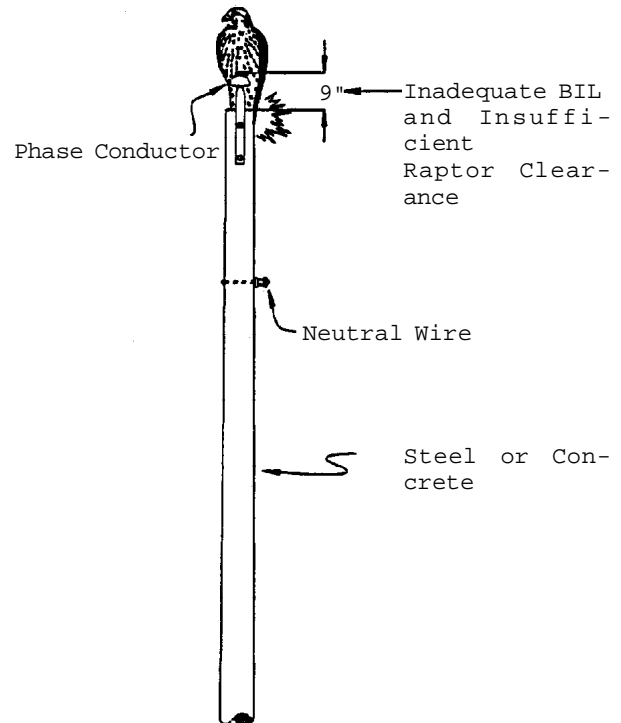

Figure 2. Inadequate BIL and raptor clearance with steel and reinforced concrete poles.

A solution to this problem is to place the phase wire on a more expensive pultruded fiberglass pin to rise up the phase conductor (Figure 2 – Option 1). Although this modification effectively restores the steel pole structure BIL to 300 kV, the fiberglass pole-top pin extension creates a new hazard to raptors. The increased distance eliminates the possibility of electrocutions to birds perching on the pin insulator, however the modification makes it possible for a raptor to perch directly below the phase wire on the grounded pole top. This new condition can be lethal to birds such as the red-tailed hawk that are sufficiently large to bridge the gap between the steel pole top and center phase wire. Therefore, steel structures using extended pole-top pins need additional modification to keep large birds off the pole top or away from the center phase.

One solution to keep birds off the pole top is the use of plastic pole caps (Figure 2 – Option 2). Steel poles are typically fitted with pole caps to prevent small birds and insects from nesting inside the structures.

The caps also minimize noise from air blowing across the pole top and keep out moisture. In preliminary tests utilizing captive raptors at the Rocky Mountain Raptor Center, a pole-top cap discouraged birds from perching because of the caps' slick surface (Photo 5). It is uncertain however how these caps will perform in the field (Harness 1998).

Cost: Providing 300kV BIL and raptor protection requires steel and concrete poles to include a pultruded fiberglass pole-top pin and a pole cap designed to discourage perching (see Table 3). Because steel poles do not require ground wires and staples, there is some savings over wood and fiberglass. However the BIL and raptor protection pushes the overall material price of the single-phase steel construction to approximately \$96.95 more than wood. The overall steel labor cost is \$14.31 less than wood. The total labor and material cost is \$82.64 more for steel.

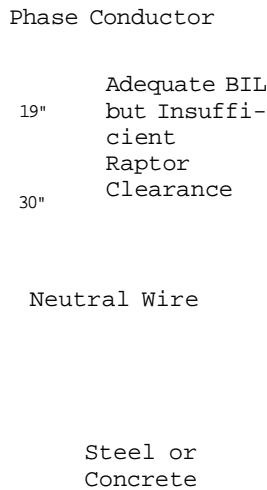

Photo 5. Distribution steel pole fitted with a pole-top cap to exclude perching.

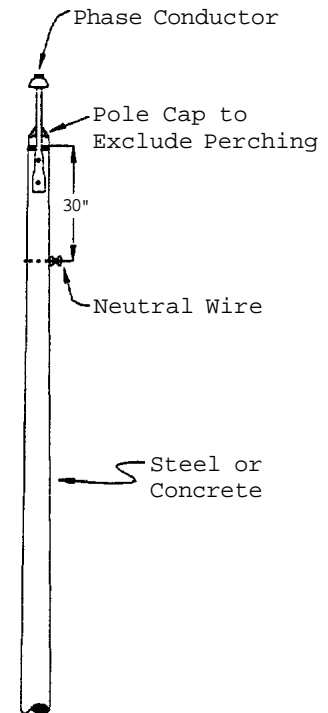

Figure 2 - Option 2. Adequate BIL due to pultruded fiberglass pole-top pin and raptor protection due to pole cap.

Figure 2 - Option 1. Adequate BIL due to pultruded fiberglass pole-top pin but insufficient raptor clearance.

Raptor Electrocutions

Table 3. Differential Costs - Single Phase Tangent Unit, Wood and Steel.

Structure Type	Description	Qty	Unit Cost	Mat. Total	Labor Cost	Structure Total
			210.00			
Wood, Raptor Safe	Wood Pole, 40-4	1	4.55	210.00	296.91	\$545.17
	Pole-top Pin	1	0.17	4.55	7.15	
	Ground Wire and Staples	30		5.10	21.46	
			280.00			
Steel, Raptor Safe	Steel Pole, 40-4	1	30.00	280.00	296.91	\$627.81
	Fiberglass Pole-top Pin	1	6.60	30.00	7.15	
	Pole-top Cap	1		6.60	7.15	

The steel pole sizes used for these examples assume a strength equivalency to wood that is based on 1997 NESC Grade B design requirements. For distribution pole lines that are designed using 1997 NESC Grade C requirements, in order for steel to be equivalent to wood, the steel poles would likely need to be 1 to 3 classes larger or would require shorter spans with more poles. For example, if a Class 4 wood pole were required for a typical tangent pole in Grade C design, the Grade B equivalent steel pole would likely have to be between a Class 3 and a Class 1 design, depending upon the overload factor used for design. This would increase the price differentials between steel and wood in these examples.

Three Phase Tangent Structures

A common three-phase distribution unit located in rural areas is a tangent structure. Figure 3 illustrates a typical three-phase tangent structure constructed on a wood or fiberglass pole. Three-phase power lines are usually constructed with an 8-foot crossarm supporting two conductors. A single energized phase conductor typically sits on a pole-top insulator. Distribution three-phase tangent structures, without pole-top grounds or pole-mounted equipment, generally provide adequate separation for all but the largest raptors since 44-inches of phase separation is provided. There is also

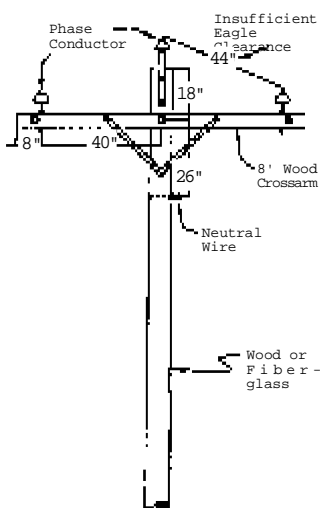

Figure 3. Typical rural distribution three-phase pole configuration, 7.2/12.47kV.

a 20-degree angle between the outer and center phase wire. This separation is appropriate in areas where large raptors are less likely to occur. Additional protection is required in areas with eagles and other large raptors.

In rural areas, three-phase tangent structures should be framed to provide an additional 16 inches of clearance, bringing the total phase-to-phase separation to 60 inches as recommended in "Suggested Practices for Raptor Protection on Power Lines: The State of the Art in 1996". The additional clearance required for eagles can be obtained by lowering the crossarm 27 inches on new poles (Figure 3 - Option W1).

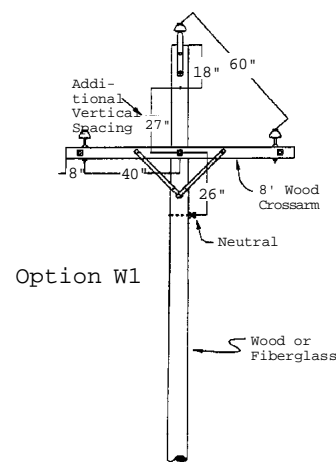
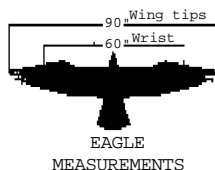

Figure 3 - Option W1. Eagle safe three-phase pole configuration using a dropped crossarm, 7.2/12.47kV.

Dropping a crossarm an additional 27 inches may require shorter spans or taller poles to maintain clearances, adding to the structure cost (see Table 4). A common alternative to dropping the arm is to use a 10-foot crossarm and lowering the arm only an additional 12 inches (Figure 3 – Option W2). This provides the recommended 60-inches of separation without using taller poles and is the most economical method to raptor-proof (see Table 4).

When steel or concrete is substituted for wood or fiberglass, the critical clearances for birds of prey becomes both the phase-to-pole (i.e. phase-to-ground) and phase-to-phase separation (Figure 4).

As in the single-phase unit, additional clearances must be met for the center pole-top phase conductor by placing the phase wire on a pultruded pole-top fiberglass pin with a pole-top cap to discourage perching.

Additionally, nonconducting wood or fiberglass crossarms should always be used. Steel crossarms on steel poles should always be avoided. Because steel poles do not require ground wires and staples, there is some material and labor savings over wood, concrete, and fiberglass. The phase-to-pole clearances can be satisfied in several ways.

The reduced phase-to-ground clearances on steel poles can be mitigated by insulating the pole top (Figure 4 - Option S1). This can be achieved by wrapping the pole top with a band of 40-mil thermoplastic polymer membrane wrap backed with a pressure sensitive adhesive above the crossarm or spraying on a protective coating that has sufficient dielectric strength. RUS requires an insulating coating of at least 15kV (RUS 2000). This is the most economical steel pole option (see Table 4).

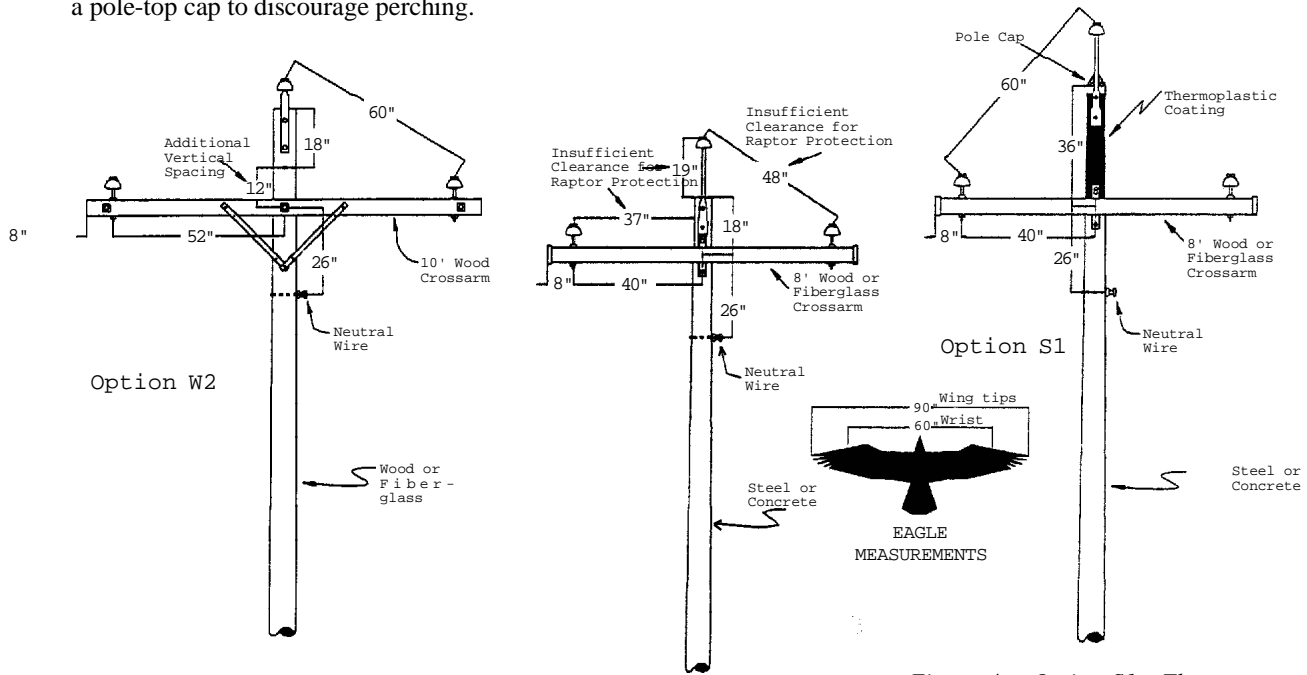

Figure 3 - Option W2. Eagle-safe three-phase pole configuration using a 10-foot crossarm, 7.2/12.47kV.

Figure 4. Three-phase steel/concrete pole configuration with inadequate raptor separation, 7.2/12.47kV.

Figure 4 – Option S1. Three-phase steel/concrete pole configuration with thermoplastic wrap, 7.2/12.47kV.

Raptor Electrocutions

Perch guards can also be mounted on crossarms to keep raptors away from the pole instead of an insulating pole wrap (Figure 4 - Option S2). Although this method can be used to discourage perching, it will not always be successful. Lines fitted with triangular perch guards are effective in reducing mortality but will not always eliminate mortality (Harness and Garrett 1999). Perch guards may also simply shift raptors to other nearby pole structures.

Another suitable method to raptor proof is to cover up the outer 2 phase conductors with a Kaddas Bird Guard™ insulator cover to prevent phase-to-pole contacts (Figure 4 - Option S3). Although the Kaddas Bird Guard™ is easily installed, this is the most costly option due to the price of the Guards (see Table 4).

An alternative to constructing lines in a traditional manner is to frame them in a form that allows safe perching (Figure 4 – Option S4). Safe perching can be accomplished by suspending two of the energized conductors under the crossarm, instead of supporting them on the arm. Option S4 requires suspension insulators and clamps. Each suspension insulator assembly (insulator, eyebolt, and shoe) costs \$5.41 more (see Table 4) than a standard pin insulator assembly (insulator, crossarm pin, and tie).

Suspending the conductors allows birds to perch on the crossarm without coming in close proximity to energized conductors. A pole-top cap must still be employed to discourage perching. Suspending the insulators and conductors will also allow utilities to achieve the Raptor Research Foundation’s recommended 60-inches with shorter crossarms.

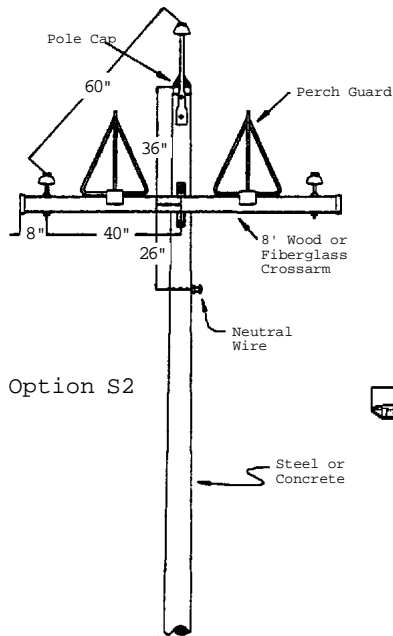

Figure 4 – Option S2. Three-phase steel/concrete pole configuration with perch guards, 7.2/12.47kV.

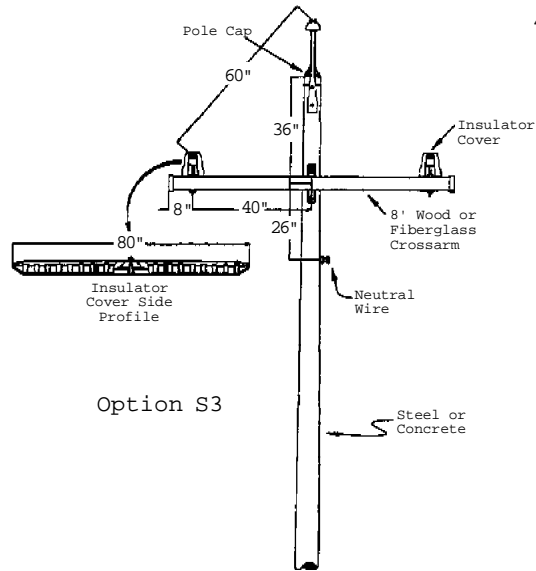

Figure 4 – Option S3. Three-phase steel/concrete pole configuration with Kaddas Bird Guards™, 7.2/12.47kV.

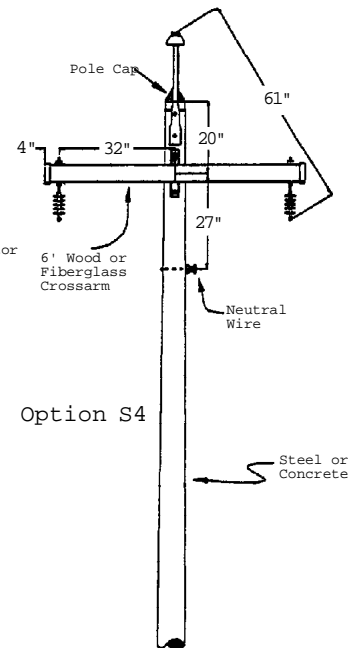

Figure 4 – Option S4. Three-phase steel/concrete pole configuration framed with adequate raptor separation, 7.2/12.47kV.

Cost: The cost analysis (see Table 4) examines six alternatives (W1, W2, S1, S2, S3, and S4) for making a typical three-phase tangent structure bird-safe.

Two wood and four steel approaches were examined on the basis of new installation. The units in Table 4 are compared using the differential material and labor cost between each option.

Table 4. Differential Costs - Three Phase Tangent Unit, Wood and Steel

Structure Type	Description	Qty	Unit Cost	Total Mat.	Total Labor	Structure Total
Wood, Raptor Safe Option W1	Wood Pole, 45-4	1	240.00	240.00	296.91	\$628.03
	Pole-top Pin	1	4.55	4.55	7.15	
	Crossarm, 8-foot	1	31.40	31.40	21.46	
	Ground Wire and Staples	30	0.17	5.10	21.46	
Wood, Raptor Safe Option W2	Wood Pole, 40-4	1	210.00	210.00	296.91	\$605.28
	Pole-top Pin	1	4.55	4.55	7.15	
	Crossarm, 10-foot	1	38.65	38.65	21.46	
	Ground Wire and Staples	30	0.17	5.10	21.46	
Steel, Raptor Safe Option S1	Steel Pole, 40-4	1	280.00	280.00	296.91	\$700.04
	Fiber Pole-top Pin	1	30.00	30.00	7.15	
	Pole-top Cap	1	6.60	6.60	7.15	
	Crossarm, 8-foot	1	31.40	31.40	21.46	
	Thermoplastic Wrap	1	5.48	5.48	13.89	
Steel, Raptor Safe Option S2	Steel Pole, 40-4	1	280.00	280.00	296.91	\$758.25
	Fiber Pole-top Pin	1	30.00	30.00	7.15	
	Pole-top Cap	1	6.60	6.60	7.15	
	Crossarm, 8-foot	1	31.40	31.40	21.46	
	Perch Guards	2	32.75	65.50	12.08	
Steel, Raptor Safe Option S3	Steel Pole, 40-4	1	280.00	280.00	296.91	\$902.75
	Fiber Pole-top Pin	1	30.00	30.00	7.15	
	Pole-top Cap	1	6.60	6.60	7.15	
	Crossarm, 8-foot	1	31.40	31.40	21.46	
	Kaddas Bird Guard™	2	105.00	210.00	12.08	
Steel, Raptor Safe Option S4	Steel Pole, 40-4	1	280.00	280.00	296.91	\$705.80
	Fiber Pole-top Pin	1	30.00	30.00	7.15	
	Pole-top Cap	1	6.60	6.60	7.15	
	Crossarm, 8-foot	1	31.40	31.40	21.46	
	Suspension insulator Diff.	2	5.41	10.82	14.31	

The steel pole sizes used for these examples assume a strength equivalency to wood that is based on 1997 NESC Grade B design requirements. For distribution pole lines that are designed using 1997 NESC Grade C requirements, in order for steel to be equivalent to wood, the steel poles would likely need to be 1 to 3 classes larger or would require shorter spans with more poles. For example, if a Class 4 wood pole were required for a typical tangent pole in Grade C design, the Grade B equivalent steel pole would likely have to be between a Class 3 and a Class 1 design, depending upon the overload factor used for design. This would increase the price differentials between steel and wood in these examples.

Raptor Electrocutions

Table 5 provides a list of the cost difference between each option. The most cost effective structure is a wood pole using a 10-foot crossarm (Option W2). Wood pole construction using a 10-foot crossarm only minimally increases material costs because it requires a standard 40-4 wood pole and standard pole-top pin.

The next most cost effective structure is using an 8-foot crossarm with a 5-foot taller pole (Option W1). The steel options increase the cost from \$94.76 to \$297.47 depending upon the material and options selected.

Table 5. Differential Costs - Three Phase Tangent Unit, Wood and Steel.

Alternative	Description	Intalled Cost Estimate	Differential	Percent Increase
Wood, Raptor Safe Option W1	Wood Pole, 45-4 Lowered Crossarm, 8-foot	\$628.03	\$22.75	4%
Wood, Raptor Safe Option W2	Wood Pole, 40-4 Crossarm, 10-foot	\$605.28	Base	Base
Steel, Raptor Safe Option S1	Steel Pole, 40-4 Fiberglass Pole-top Pin, Pole-top Cap Thermoplastic Wrap	\$700.04	\$94.76	16%
Steel, Raptor Safe Option S2	Steel Pole, 40-4 Fiberglass Pole-top Pin, Pole-top Cap Perch Guards	\$758.25	\$152.97	25%
Steel, Raptor Safe Option S3	Steel Pole, 40-4 Fiberglass Pole-top Pin, Pole-top Cap Kaddas Bird Guard™	\$902.75	\$297.47	49%
Steel, Raptor Safe Option S4	Steel Pole, 40-4 Fiberglass Pole-top Pin, Pole-top Cap Suspension Insulator Diff.	\$705.80	\$100.52	17%

Deadend Structures

Deadend structures accommodate directional changes and lateral taps. The 300kV BIL level is especially important on deadends where voltage doubling can occur. The 300kV BIL can be attained on steel and concrete poles by installing a 24-inch (minimum length) insulated extension links between the primary deadend suspension insulators and the steel pole (Photo 6). The insulating links cost \$12.75 each. The insulating links are not required to achieve 300kV BIL on wood or fiberglass structures.



Photo 6. Steel single-phase double deadend pole with insulating links to achieve 300kV BIL.

Equipment Structures

Distribution facilities contain an array of pole-mounted equipment such as transformers, capacitors, regulators and reclosers. Although equipment poles are relatively widely spaced on most rural electric systems, they are associated with a disproportionate number of detected raptor electrocutions (Harness 1997). Uninsulated jumper wires connect the primary phase and neutral conductors to the pole-mounted equipment. The spacing of these bare jumper wires can present a hazard to both small and large raptors.

Equipment mitigating measures are similar for all pole types. Installing raptor-safe equipment includes bushing covers, insulated jumper wires (600 Volt class insulation), and bird spikes between cutout/arresters (Photo 8).

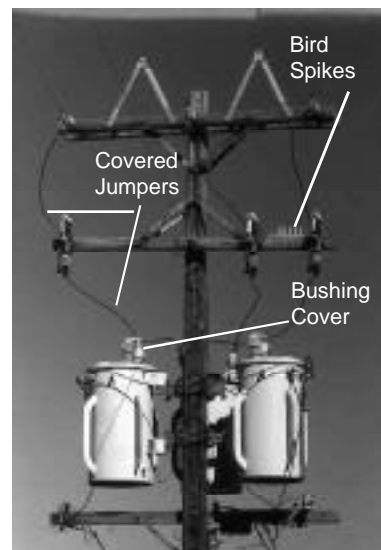

Photo 8. Retrofitted three-phase transformer bank.

Deadend structures can be lethal to animals due to bare jumpering between circuits (Photo 7). Insulating jumper wires is the most common raptor proofing method. On some structures jumper wires can simply be rerouted under crossarms to eliminate potential phase-to-phase contacts. These mitigating measures are typically similar, regardless of pole type.



Photo 7. Deadend structure with inadequate separation between jumper wires.

Raptor Electrocutions

Conclusion

When comparing different pole types, additional materials required to frame poles in a raptor-safe manner should be included in a cost analysis. The cost to provide established engineering criteria such as Basic Impulse Insulation Level should also be considered. Because steel and reinforced concrete poles are more conductive than wood or fiberglass, additional costs are required to provide adequate BIL and raptor protection.

Single-phase and three-phase tangent structures are the common structure types in rural areas. Typical single-phase tangent units constructed with wood poles without pole-top grounds or pole-mounted equipment are raptor safe. However, the same single-phase configuration with steel or reinforced concrete poles requires additional measures to provide raptor protection and 300kV BIL. Additional construction methods typically include the use of fiberglass pole-top pin extensions and pole-top caps to exclude perching. These additional measures add approximately \$12.64 in material and labor costs per pole. The total labor and material increase between a single-phase raptor-safe wood pole and a raptor-safe steel pole is approximately \$82.64 when factoring in the additional steel pole cost.

Typical three-phase tangent units constructed with wood poles with wood crossarms also require measures to make them raptor-safe. The most economical remedy is to construct new wood pole units with 10-foot wood crossarms, providing 60-inches of separation. The same three-phase configuration on steel or reinforced concrete poles requires additional measures to provide raptor protection and 300kV BIL. Additional construction methods include the use of fiberglass pole-top pin extensions, pole-top caps to exclude perching, and either pole-top insulating materials or covers, or perch guards. The most economical way to raptor proof steel and concrete poles is insulating the pole top with either a thermoplastic wrap or spray-on coating. These additional measures add approximately \$24.76 in material and labor costs per pole. The total labor and material increase between a three-phase raptor-safe wood pole and a raptor-safe steel pole is approximately \$94.76 when factoring in the additional steel pole cost.

The total labor and material increase between a three-phase raptor-safe wood pole (Wood Option-W2) and a raptor-safe steel pole will range from approximately \$94.76 to \$297.47 (Steel Option-S1, Steel Option-S3) depending on the technology chosen.

For convenience this analysis was based on NESC 1997 Grade B design, when in fact Grade C construction is most common for distribution systems and the cost differentials would be greater as larger or more steel poles are needed to be equivalent to wood Grade C design.

References

- Abbey, M., A. Stewart and J. Morrell. 1997. Existing strategies for control/remediation of woodpecker damage. Proceedings of a workshop on the mitigation of woodpecker damage to utility lines sponsored by the Electric Power Research Institute.
- APLIC (Avian Power Line Interaction Committee). 1996. *Suggested Practices for Raptor Protection on Power Lines: The State of the Art in 1996*. Edison Electric Institute/Raptor Research Foundation. Washington, D.C. 125 pp.
- Benson, P.C. 1981. Large raptor electrocution and power line utilization: a study in six western states. Ph.D. Dissertation. Brigham Young University, Provo, Utah. 98 pp.
- Bevenger, K. 1994. Bird interactions with utility structures: collision and electrocution, causes and mitigating measures. *Ibis* 136:412-425.
- Boeker, E.L. 1972. Power lines and bird electrocutions. Unpublished report. U.S. Fish and Wildlife Service, Denver Wildlife Research Center. Denver, Colorado. 8 pp.
- Dawson, J.W. and R.W. Mannan. 1995. Electrocution as a mortality factor in an urban population of Harris' hawks. *Journal of Raptor Research* 29. 55.

- Ferrer, M. and H. Fernando. 1991. Evaluation of management techniques for the Spanish imperial eagle. *Wildlife Society Bulletin* 19: 436-442.
- Ferrer, M., M. De La Riva, and J. Castroviejo. 1991. Electrocutation of raptors on power lines in southwestern Spain. *Journal of Field Ornithology* 62(2): 181-190.
- Graham Jr., F. 2000. *The Day of the Condor*. Audubon. January - February 2000. 47-53.
- Harness, R.E. and M. Garrett, 1999, Effectiveness of perch guards to prevent raptor electrocutions, *Journal of the Colorado Field Ornithologists* Vol. 33, No. 4: 215-220.
- Harness, R.E. 1998, Steel distribution poles – environmental implications. Pages D1-1 – D1-5 in *Proc. of the Rural Electric Power Conference*. Institute of Electrical and Electronics Engineers, New York, N.Y.
- Harness, R.E. 1997, Raptor electrocutions caused by rural electric distribution power lines. M.S. thesis. Colorado State University, Fort Collins, Colorado. 110 pp.
- Hass, D. 1980. Endangerment of our large birds by electrocution – a documentation. Pages 7-57 in *Okologie der vogel*. Vol. 2 Deutscher bund fur Vogelschutz, Stuttgart.
- Herren, H. 1969. Status of the peregrine falcon in Switzerland. Pages 231–238 in J.J.
- Institute of Electrical and Electronics Engineers (IEEE) Power Engineering Society. IEEE guide for animal deterrents for electric power supply substations. Institute of Electrical and Electronics Engineers, Inc., New York. 16 pp.
- Janns, G.F.E. and M. Ferrer. 1999. Mitigation of raptor electrocution on steel power poles. *Wildlife Society Bulletin*, 27(2):263-273.
- Jarvis, M. J. F. 1974. High tension power lines as a hazard to larger birds. *Ostrich*. 45: 262.
- LaRoe, E.T., G.S. Farris, C.E. Puckett, P.D. Doran and M.J. Mac (Eds.). 1995. Our living resources: a report to the nation on the distribution, abundance and health of U.S. plants, animals and ecosystems. U.S. Department of the Interior, National Biological Service, Washington, D.C. 530 pp.
- Ledger, J.A. and H.J. Annegarn. 1981. Electrocutation hazards to the Cape vulture *Gyps coprotheres* in *South Africa*. *Biological Conservation* 20: 15-24.
- Markus, M.B. 1972. Mortality of vultures caused by electrocution. *Nature* 238: 228.
- Melcher, C. and L. R. Suazo. 1999. *Raptor Electrocutations: The Unnecessary Losses Continue*. *Journal of the Colorado Field Ornithologists*. 33:221-224.
- Negro, J.J. and M. Ferrer. 1995. Mitigating measures to reduce electrocution of birds on power lines: a comment on Bevanger's review. *Ibis*:137(3): 423-424.
- Nelson, M.W. and P. Nelson. 1976. Power lines and birds of prey. *Idaho Wildlife Review*. 28(5): 3-7.
- Nelson, M.W. 1977. Preventing electrocution deaths and the use of nesting platforms on power poles. *Hawk Trust Annual Report*. 8: 30-33.
- Nelson, M.W. 1979a. Update on eagle protection practices. Unpublished report. Boise, Idaho. 14 pp.
- Nelson, M.W. 1979b. Power lines progress report on eagle protection research. Unpublished report. Boise, Idaho. 13 pp.
- Nikolaus, G. 1984. Large numbers of birds killed by electric power lines. *Scopus* 8: 42.

Raptor Electrocutions

- Olendorff, R.R. 1972. Eagles, sheep and power lines. *Colorado Outdoors*. 21: 3-11.
- Olendorff, R.R., A. D. Miller, and R. N. Lehman. 1981. *Suggested Practices for Raptor Protection on Power Lines: The State of the Art in 1981*. Raptor research report no. 4, Raptor Research Foundation, University of Minnesota, St. Paul, Minnesota. 111 pp.
- Olendorff, R.R. 1993. Eagle electrocution. In *Proceedings: Avian interactions with utility structures. International workshop. Electric Power Research Institute, Palo Alto, California. Section 6 EPRI TR-103268 Project 3041*.
- Rural Utilities Service (RUS). 2000. Draft - RUS guidelines and approval for use of distribution steel poles (Version 5). USDA, Washington D.C. 6 pp.
- Southern Engineering Company. 1996. Animal-caused outages. National Rural Electric Cooperative Association. Arlington, Virginia. 171 pp.
- Suazo, L. R. 1998. *Power lines and Raptors: Using Regulatory Influence to Prevent Electrocutions*. Paper presented at Fifth World Conference on Birds of Prey and Owls. Midrand, South Africa.
- United States of America v. Moon Lake Electrical Association*; 45 F.Supp..2d 1070 (1999).
- Williams, T. 2000. *Zapped!* Audubon. January - February 2000. 32-44.

Disclaimer

The North American Wood Pole Coalition and its members believe the information contained herein to be based on up-to-date scientific information. In furnishing this information, the NAWPC and the author make no warranty or representation, either expressed or implied, as to the reliability or accuracy of such information; nor do NAWPC and the author assume any liability resulting from use of or reliance upon the information by any party. This information should not be construed as a recommendation to violate any federal, provincial, state, or municipal law, rule or regulation, and any party using poles should review all such laws, rules, or regulations prior to doing so.

North American Wood Pole Coalition

American Wood Preservers Institute
703-204-0500

Canadian Institute of Treated Wood
613-737-4337

Southern Pressure Treaters Association

703-204-0500

Western Red Cedar Pole Association
800-410-1917

Western Wood Preservers Institute
800-729-9663